

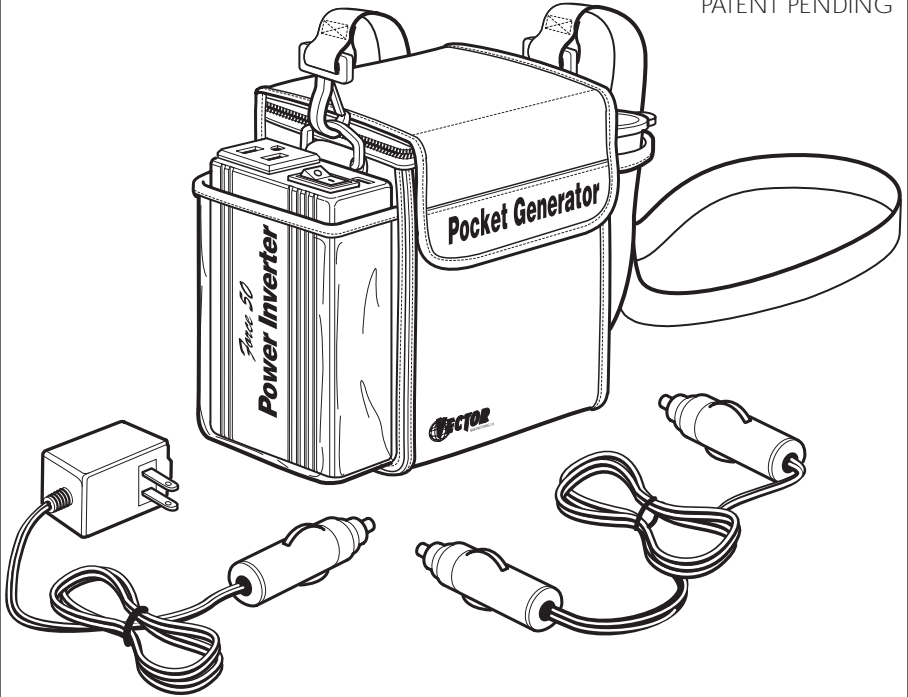

VEC018-AC

**POCKET GENERATOR™  
PORTABLE/CORDLESS/RECHARGEABLE  
POWER SUPPLY  
110-VOLT AC & 12-VOLT DC**

PATENT PENDING



**OWNER'S MANUAL  
& WARRANTY INFORMATION**

THIS MANUAL CONTAINS IMPORTANT INFORMATION REGARDING SAFETY, OPERATION, MAINTENANCE AND STORAGE OF THIS PRODUCT.

PLEASE READ THIS INSTRUCTION MANUAL CAREFULLY BEFORE

3003 Greene St., Hollywood, FL 33020  
Tel: (954) 923-1155 • Fax: (954) 923-8111

---

## INTRODUCTION

Thank you for choosing the Vector™ **Portable/Cordless/Rechargeable Pocket Generator™**. Please read this guide carefully before use to ensure optimum performance and avoid damage to the unit or items that you are using it with. For easy reference, all information and specifications pertaining to the **Pocket Generator™** as a complete unit are listed at the front of this manual. All information and specifications pertaining to the **Power Force 50™** power inverter, are listed at the back of the manual.

The **Pocket Generator™** is a convenient, easy-to-carry, completely portable source of electricity designed to operate either 110-volt AC or 12-volt DC appliances or accessories in areas where permanent utility power sources are not available. It is ideal for use with Vector™ 12-volt DC cordless/portable/rechargeable products.

The **Pocket Generator™** can be used to:

**Operate:** 12-volt DC

Fans, inflators, fluorescent worklights, cellular phones\*, air compressors, spotlights, TVs, portable radios, cassette or CD players, and more.

*\*Can quick-charge a cellular phone by using the phones 12-volt DC adapter cord.*

**Operate:** 110-volt AC

Laptop computers and printers, reading lamps, fans, and more.

**Recharge:** 110-volt AC

Small 110-volt AC devices (laptop computers, cellular phones, camcorders, power tool batteries) that have an appropriate recharging adapter with a 110-volt AC standard-type plug.

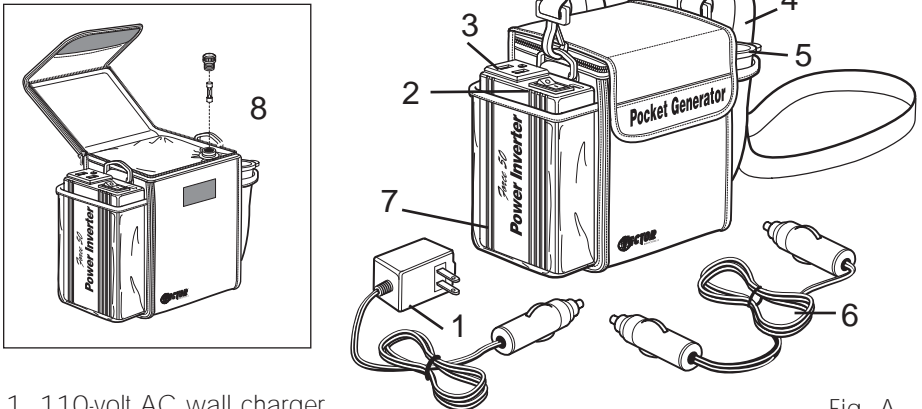

Fig. A.

1. 110-volt AC wall charger
2. ON/OFF switch for 50-watt power inverter
3. 110-volt AC power outlet
4. Shoulder strap
5. 12-volt DC power outlet
6. 12-volt DC vehicle charger (or, battery booster/memory saver)
7. 50 watt power inverter
8. Fuse

---

# **Pocket Generator™** Portable/Cordless/Rechargeable Power Supply

## SYSTEM FEATURES

- Take your home or office appliances and electronics with you - portable source of 12-volt DC power or 110-volt AC power - ideal for use anywhere that 110-volt utility power is unavailable or inconvenient.
- Includes Vector™ **Power Force 50™ inverter**.
- Powers or charges portable appliances, tools, and electronic devices - cell phones, camcorders, laptop computers, lamps, fans, radios, TV/VCRs, CD players, worklights, etc. (12-volt DC or 110-volt AC).
- Easy recharging from vehicle, boat or RV 12-volt DC accessory outlet, or 110-volt AC household wall socket (AC and DC charging adapters included).
- Equipped with in-line 10-amp fuse to protect the unit and any devices it is powering or recharging.
- Compact, sturdy, lightweight design.
- Water-resistant, padded case - with belt holster and removable shoulder strap.
- Built-in 12-volt plug-in receptacle (cigarette lighter-type).
- Easy-to-use emergency power supply to boost low battery system in vehicle, RV, boat (note: will not recharge a completely dead vehicle battery).
- Use as a Memory Saver - protects pre-set electronic settings for seats, radio, A/C, etc., if battery power is to be disconnected for repair/maintenance.
- High surge capacity: 50-watt continuous power - 80-watt peak.
- Low power consumption ensures longer battery life.
- Built-in, single 110-volt AC receptacle.
- Electronic circuit protection prevents damage due to overload/insufficient ventilation.
- Low-battery shutdown automatically occurs when battery discharges to 10.6-volts, preventing battery damage.
- Includes 5 amp hour 12-volt sealed lead acid battery system.

## CAUTIONS:

1. Completely charge the **Pocket Generator™** before using it for the first time.
2. The AC and DC chargers provided with this unit should never be used with any other device - they are designed specifically for use with the **Pocket Generator™**.
3. Never attempt to recharge the **Pocket Generator™** using any recharger other than the ones supplied.
4. Always use the **Pocket Generator™** on a stable, flat surface and be sure that there is adequate ventilation.
5. Do not use the **Pocket Generator™** near flammable materials or in locations that may accumulate flammable fumes or gases.

*Continued on next page...*

- 
6. **WARNING:** Do not run both AC and DC devices at the same time.
  7. **ALWAYS** turn OFF the **Power Force 50™** inverter BEFORE charging the **Pocket Generator™**.
  8. The nylon case that is provided with the **Pocket Generator™** is water-resistant only to the extent that it will help protect the unit from rain or water spray; never immerse the unit in water (fresh or salt).
  9. Do not expose the **Pocket Generator™** to extreme heat or flames.
  10. Do not exceed recommended charging times.
  11. Continuous run times are limited, see charts for estimated operation times.

## RECHARGING THE **Pocket Generator™**

### CAUTION:

- **IMPORTANT:** Before recharging from an AC power source, verify that the source is 110-volts only. Do not plug this unit's 110-volt charger into a 220-volt power source.
- **IMPORTANT:** Be sure that power inverter ON/OFF switch is in OFF position before recharging.

### Recharging From A 110-volt AC Power Source

1. Before initial use, it will take 18-20 hours to fully charge the **Pocket Generator™**. Subsequent charges will only take 12-15 hours (approx.).
2. Insert the cigarette lighter plug at the end of the AC charger cord into the matching 12-volt receptacle on the side of the **Pocket Generator™**.
3. Plug the charger into any standard 110/120-volt AC electrical outlet. Never plug a 110-volt charger into a 220-volt power source.

### Recharging From A 12-volt DC Power Source

### CAUTION:

Do not connect the **Pocket Generator™** DC charger to a car or boat electrical system (12-volt DC negative-ground only) without first starting the engine. Failure to do so could damage the vehicle's battery.

1. Insert the cigarette lighter plug at one end of the DC charger cord into the matching 12-volt receptacle on the side of the **Pocket Generator™**.
2. Insert the cigarette lighter plug at the other end of the cord into the vehicle's cigarette lighter receptacle. Rotate the plug slightly to ensure good contact. A green L.E.D. light on the cigarette plug will indicate a proper connection.
3. The **Pocket Generator™** should be charged initially for 4-6 hours, while driving, before use. Subsequent charges should only require 2-4hours (approx.).
4. The DC charging system will not provide as full a charge as is obtained with a 110-volt charging system.

---

**Note: Vector™ recommends charging from a vehicle only while its engine is running, so as not to run down the vehicle's battery. The ideal charging rate is 14.5-15.5 volts, which is nearly identical to the charging rate of most vehicle batteries.**

## OPERATION

Estimated run-times.

---

12-VOLT DC APPLIANCE	APPROX. RUNNING TIME
CELL PHONE, FLORESCENT LIGHT	6-12 HOURS
RADIO, FAN, DEPTH FINDER	5 HOURS
CAMCORDER, VCR, SPOTLIGHT	2.5 HOURS
ELECTRIC TOOLS, BILGE PUMP	1 HOUR
INFLATOR/RAFT	50 MINUTES
AIR COMPRESSOR	25 MINUTES

---

110-VOLT AC APPLIANCE	APPROX. RUNNING TIME
50 WATT LAMP	40 MINUTES
LAPTOP / PRINTER	1.5 HOURS
DESK FAN	2.0 HOURS
STEREO/CD PLAYER	2.5 HOURS
CELLULAR PHONE, POWER TOOLS & CAMCORDER CHARGERS	5 TO 10 HOURS

---

---

## 110-volt AC Operation

### CAUTION: Rechargeable Devices

Certain rechargeable devices are designed to be recharged by plugging them directly into an AC receptacle. These devices may damage the inverter unit of the **Pocket Generator™**. When first using a rechargeable device, monitor its temperature for the initial ten minutes of use to determine whether it emits excessive heat. If excessive heat is detected, it is a good indication that the device should not be used with this unit. This problem does not occur with the majority of battery-operated equipment. Most of these devices use a separate charger or transformer that is plugged into an AC receptacle. The **Pocket Generator™** is capable of running most chargers and transformers.

1. Make sure that the ON/OFF switch on the inverter is in the OFF position.
2. Insert the 110-volt AC plug on the device to be operated into the AC outlet on the power inverter.
3. Turn the power inverter's ON/OFF switch to ON.
4. Switch on the device, and operate as usual. Run-time depends upon the amperage draw of the device (see charts).
5. Green power/ON light next to switch will be lit.

## 12-volt DC Operation

### WARNINGS

- When using the **Pocket Generator™ Rechargeable Power Supply** to run 12-volt devices, always check the polarity of the device to verify that it is negative ground. The **Pocket Generator's™** DC receptacle has an output limit of 10 amps; do not use it to power devices that require more than 10 amps. **Note:** The unit has an in-line 10-amp fuse that is designed to fail in the event the unit is used with any device requiring more than 10 amps.
  - Always turn the power inverter switch to OFF position while running any 12-volt device, boosting vehicle battery system, using as Memory Saver, or recharging the **Pocket Generator™** from either 110-volt AC or 12-volt DC power source. **Failure to do so will void manufacturer's warranty.**
1. Simply insert the device's 12-volt plug into the DC receptacle on the side of the **Pocket Generator™**.
  2. Switch on the device, and operate as usual. Run-time depends upon the amperage draw of the device.
  3. When necessary, recharge the **Pocket Generator™**, as directed in this manual.

---

## To Use The *Pocket Generator™* To Boost Vehicles Low Battery System

**WARNING:** Be sure that the ON/OFF switch on the inverter is in the OFF position, before using unit as Battery Booster. Failure to do so may cause damage to the inverter, and will void manufacturer's warranty. **Note:** The *Pocket Generator™* will not fully charge a completely dead battery, but it can be used to boost a vehicle's weak battery system, or to provide auxiliary power for the onboard electrical systems and selected memory settings for electronics (A/C, seats, radio, etc.). Using the adapter cord with two cigarette lighter-type plugs, insert one end of the cord into the vehicle's cigarette lighter receptacle, and the other end into the corresponding receptacle on the *Pocket Generator™*. When power assist is completed, disconnect the adapter cord's plugs from the vehicle's cigarette lighter receptacle and the *Pocket Generator™*.

## To Use The *Pocket Generator™* As A Memory Saver For Onboard Systems And Pre-Sets

**WARNING:** Be sure that the ON/OFF switch on the inverter is in the OFF position, before using unit as Memory Saver. Failure to do so may cause damage to the inverter, and will void manufacturer's warranty. When the vehicle's battery system is to be disconnected for repair or maintenance, the *Pocket Generator™* will provide auxiliary power to maintain the selected memory settings and other onboard electrical systems, until power is restored. BEFORE the vehicle's battery system is disconnected: using the adapter cord with two cigarette lighter-type plugs, insert one end of the cord into the vehicle's cigarette lighter receptacle, and the other end into the corresponding receptacle on the *Pocket Generator™*. Onboard power will be maintained. AFTER the vehicle's battery system is reconnected, disconnect the adapter cord's plugs from the vehicle's cigarette lighter receptacle and the *Pocket Generator™*.

## Fuse Replacement

### Main Fuse

1. Open the top flap of the *Pocket Generator™*, carrying case. The main fuse holder's screw-on/off cap will immediately be visible.
2. Unscrew the fuse holder cap and remove the fuse.
3. Replace with a new 10-amp fuse, if needed.
4. Screw fuse holder cap back on.
5. Close case securely.

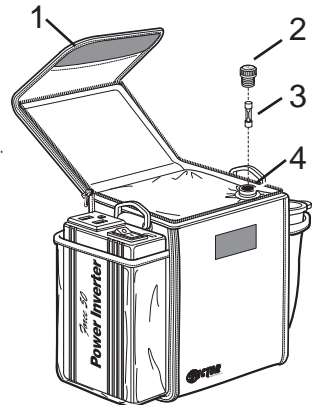

Fig. B.

---

## Storage

- Ideal storage temperature range is 50-68°F (10-20°C).
- Store the **Pocket Generator™** in a cool, dry place with adequate ventilation for all-around air circulation.
- Avoid locations that are exposed to heating units, radiators, direct sunlight, or excessive humidity or dampness.
- To maximize useful life, fully charge the unit before storing.
- If storing at less than 50°F, recharge every six months; at 50-80°F, recharge every three months; at 80-104°F, recharge every 45 days.
- Always make sure the unit is disconnected from charger before storing.

## SPECIFICATIONS: **Pocket Generator™**

AC Output	110-volts
DC Output	12-volts
Fuse	10 amps
Battery	12-volt 5 amp hour sealed lead acid, maintenance-free
Inverter	50-watts continuous/80 amps peak surge capacity
Weight:	4.60lbs.
Height:	6.25"
Depth:	4.00"
Width:	7.50"

## **Power Force 50™** Inverter

**WARNING:** Do not attempt to remove the inverter from the unit for any reason - it is hard-wired into the unit, and you may cause unnecessary damage to the unit and void the manufacturer's warranty. In the event of any failure, refer to the warranty information at the back of this manual and return the complete unit for repair or replacement, or call the customer service department at Vector Manufacturing, Ltd. (954) 923-1155.

The Vector™ **Power Force 50™** inverter supplied with the **Pocket Generator™** is one in a series of the most advanced DC to AC inverters available today. With proper care and maintenance, it will deliver years of dependable service. For easy reference, see sections titled:

Introduction

How the **Power Force 50™** Inverter Works

Power Source Requirements

Fuse Replacement

Operating Tips

Troubleshooting

Specifications



---

## INTRODUCTION

The **Power Force 50™** supplies 50-watts of continuous power, with an 80-watt peak, via a household-type outlet that is ready to deliver 110-volt AC power whenever and wherever it is needed. Simply, fully charge before use and turn ON the power switch to operate small electronic devices such as laptop computers, portable radio/cassette/CD players, color TVs (up to 50 watts), cellular phone and camcorder battery chargers, and more.

The **Power Force 50™** is equipped with an ON/OFF switch and power/charging indicator light. The AC receptacle is fully marinated, weather-proof and fused. Added safety features include:

- electronic circuit protection that prevents damage due overloading or insufficient ventilation;
- automatic shutdown to prevent damage to vehicle's battery.

Please read the following information carefully before use, to ensure reliable service and complete safety. Pay particular attention to the CAUTION and WARNING statements that are provided.

## HOW THE **Power Force 50™** INVERTER WORKS

The **Power Force 50™** inverter is an electronic device that converts low voltage DC (direct current) electricity from a battery to standard 110-volt AC (alternating current) household power. In designing the **Power Force 50™**, Vector™ has incorporated design techniques previously employed in computer power supplies. The result of these design innovations is a smaller, lighter and easier-to-use power inverter.

### Principle Of Operation

The **Power Force 50™** inverter converts power in two stages. The first stage is a DC-to-DC conversion process that raises the low voltage DC at the inverter input to 14.5-volts DC. The second stage is the actual inverter stage that converts the high voltage DC into 110-volts, 60 Hz AC.

The DC-to-DC converter stage uses modern high frequency power conversion techniques that have replaced the bulky transformers found in less technologically advanced models. The inverter stage uses advanced power MOSFET transistors in a full bridge configuration. This ensures excellent overload capability and the ability to operate reactive loads like lamp ballasts and small induction motors.

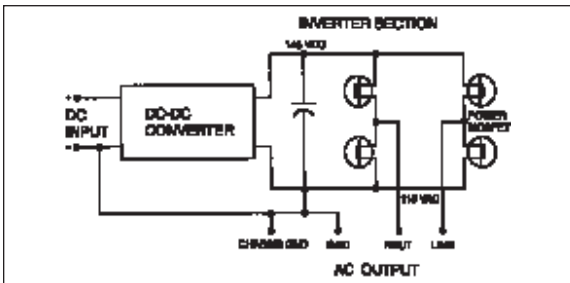

Figure 1.

Vector™ **Power Force 50™**  
Inverter - Principle of  
Operation

---

## Power Force 50™ Output Waveform

The AC output waveform of the **Power Force 50™** is known as a “quasi-sine wave” or a “modified sine wave”. It is a stepped waveform that is designed to have characteristics similar to the sine wave shape of utility power. This type of waveform is suitable for most AC loads, including linear and switching power supplies used in electronic equipment, transformers, and motors.

The modified sine wave produced by the **Power Force 50™** inverter is designed to have an RMS (root mean square) voltage of 110 volts, which is the same as standard household power. Most AC voltmeters (both digital and analog) are sensitive to the average value of the waveform rather than the RMS value. They are calibrated for RMS voltage under the assumption that the waveform measured will be a pure sine wave. These meters will not read the RMS voltage of a modified sine wave correctly. They will read about 20 to 30 volts low when measuring the output of the **Power Force 50™**. For accurate measurement of the output voltage of this unit, use a true RMS reading voltmeter such as a **Fluke 87**, **Fluke 8080A**, **Beckman 4410**, or **Triplett 4200**.

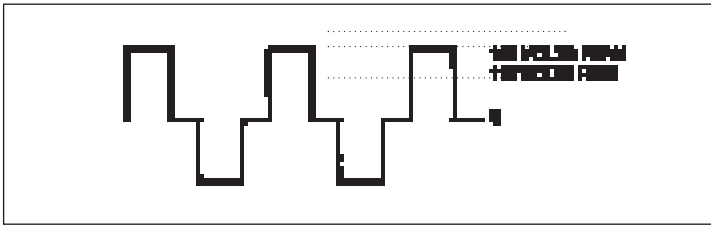

Figure 2: Power Force 50™ - Modified Sine Wave

## POWER SOURCE REQUIREMENTS

The **Pocket Generator™** battery must provide between 10.5 and 14.5 volts DC and must be able to supply the necessary current to operate the load. To obtain a rough estimate of the current (in amperes) the power source must deliver, simply divide the power consumption of the load (in watts) by 10.

Example: If a load is rated at 50 watts, the power source must be able to deliver:

$$50 \div 10 = 5 \text{ amperes}$$

## Connection To Load

Connect the **Pocket Generator™** to the vehicle's cigarette lighter socket using the cigarette lighter plug provided. The **Power Force 50™** is equipped with a standard AC household-type receptacle. Plug the cord from the equipment to be operated into the AC receptacle. The green LED indicator will illuminate to indicate that the unit is functioning. Make sure the load requirements of your equipment are within the parameters of the **Power Force 50™** output. If so, turn on the equipment.

---

## CAUTION:

### DO NOT CONNECT TO AC DISTRIBUTION WIRING:

The **Power Force 50™** is engineered to be connected directly to standard electrical and electronic equipment in the manner described above. Do not connect the Power Inverter to household or RV AC distribution wiring. Do not connect the Power Inverter to any AC load circuit in which the neutral conductor is connected to ground (earth) or to the negative of the DC (battery) source.

## CAUTION:

### RECHARGEABLE APPLIANCES

Certain rechargeable devices are designed to be recharged by plugging them directly into an AC receptacle. These devices may damage the **Power Force 50™**. When first using a rechargeable device, monitor its temperature for the initial ten minutes of use to determine whether it emits excessive heat. If excessive heat is detected, it is a good indication that the device should not be used with this inverter. This problem does not occur with the majority of battery-operated equipment. Most of these devices use a separate charger or transformer that is plugged into an AC receptacle. The **Power Force 50™** is capable of running most chargers and transformers.

### FUSE REPLACEMENT

If the **Power Force 50™** is overloaded, replace the main fuse as follows:

1. Open the top flap of the **Pocket Generator™**, carrying case. The main fuse holder's screw-on/off cap will immediately be visible.
2. Unscrew the fuse holder cap and remove the fuse.
3. Replace with a new 10-amp fuse, if needed.
4. Screw fuse holder cap back on.
5. Close case securely.

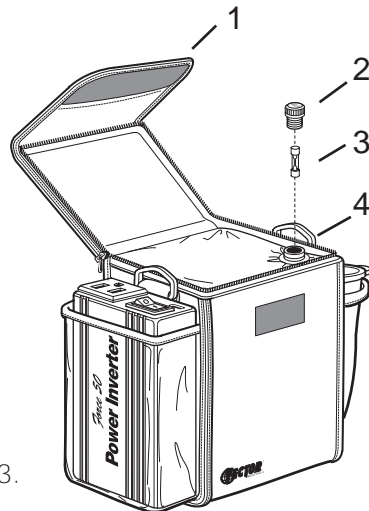

Fig. 3.

---

## OPERATING TIPS

The **Power Force 50™** should only be operated in locations that meet the following criteria:

**DRY** - Do not allow water or other liquids to come into contact with the inverter.

**COOL** - Ambient air temperature should be between -20°C and 40°C - ideally between 15°C and 25°C (60 - 80°F). Do not place the inverter on or near a heating vent or any piece of equipment which is generating heat above room temperature. Keep the inverter away from direct sunlight, if at all possible.

**VENTILATED** - Keep the area surrounding the **Power Force 50™** clear to ensure free air circulation around the unit. Do not place items on or over the inverter during operation. The unit will shut down if the internal temperature exceeds 90°C. Restart the unit once it cools down sufficiently.

**SAFE** - Do not use the **Power Force 50™** near flammable materials or in any locations that may accumulate flammable fumes or gases.

## Rated Versus Actual Current Draw of Equipment

Most electrical tools, appliances, electronic devices and audio/visual equipment have labels that indicate the power consumption in amps or watts. Be sure that the power consumption of the item to be operated is below 50 watts. If the power consumption is rated in amps, simply multiply by the AC volts (110) to determine the wattage.

Resistive loads are the easiest for the **Power Force 50™** to run; however, it will not run larger resistive loads (such as electric stoves and heaters) which require far more wattage than the **Power Force 50™** can deliver on a continuous basis. Inductive loads (such as TVs and stereos) require more current to operate than do resistive loads of the same wattage rating. Induction motors, as well as some TVs, may require 2 to 6 times their wattage rating to start up. The most demanding in this category are those that start under load, such as compressors and pumps. Testing is the only definitive way to determine whether a specific load can be started and how long it can run. For safety reasons, the unit will simply shut down if it is overloaded. To restart the unit after a shutdown due to overloading, momentarily turn off the power to the unit.

**Note: The Power Force 50™ will not operate appliances and equipment that generate heat, such as hair dryers, microwave ovens, and toasters.**

---

## Battery Operating Time

1. Always turn power switch on the inverter to OFF position when unit is not in use. If the switch is left in the ON position, it will drain the **Pocket Generator™** battery.
2. **WARNING: Never run both AC and DC devices at the same time as this can damage the Pocket Generator™.**
3. Always recharge unit after using.

With a full charge, the **Power Force 50™** inverter will deliver a minimum operating time of 30 minutes to one hour. In most instances, 1-3 hours of operating time is achievable (see chart below).

## Estimated Operation Times:

---

110-VOLT AC APPLIANCE	APPROX. RUNNING TIME
50 WATT LAMP	40 MINUTES
LAPTOP / PRINTER	1.5 HOURS
DESK FAN	2.0 HOURS
STEREO/CD PLAYER	2.5 HOURS
CELLULAR PHONE, POWER TOOLS & CAMCORDER CHARGERS	5 TO 10 HOURS

---

## TROUBLESHOOTING

### Protective Features of the **Power Force 50™**

The **Power Force 50™** monitors the following potentially hazardous conditions:

**Low Battery Voltage** - this condition is not harmful to the inverter but could damage the power source, so the inverter automatically shuts down when input voltage drops to 10.0 volts. When this condition is corrected, the unit may be restarted.

**Over Voltage Protection** - the **Power Force 50™** will automatically shut down when the input voltage exceeds 15 volts DC.

**Short Circuit Protection** - Reverse polarity or a short circuit condition will usually result in failure of the inverter's fuse. Immediately disconnect the shorted load and replace the fuse inside the **Pocket Generator™**.

---

## Common Audio/Visual Problems

### Problem: Buzzing Sound In Audio Systems

Some inexpensive stereo systems and "boom boxes" emit a buzzing sound from their speakers when operated from the **Power Force 50™** inverter, because the power supply in the electronic device does not adequately filter the modified sine wave produced by the inverter. The only solution to this problem is to use a sound system that has a higher quality power supply internally.

### Problem: Television Interference

The Vector™ **Power Force 50™** is shielded to minimize interference with TV signals. However, in some instances, some interference may still be visible, particularly when the TV signal is weak. Try the following corrective measures:

- Position the **Pocket Generator™** as far as possible from the TV set, the antennae, and the antennae cables. Use an extension cable, if necessary.
- Adjust the orientation of the **Pocket Generator™**, the antennae cables, and the TV power cord to minimize interference.
- Make sure that the antennae feeding the TV provides an adequate ("snow free") signal and that high quality, shielded antennae cable is used.

## Common Power Output Problems

### Problem: Lack Of Power Output

---

Possible Causes	Recommendations
Inverter not adequately warmed up.	Turn power inverter switch OFF and then ON again. Repeat if necessary.
Battery voltage below 10 volts.	Recharge or replace <b>Pocket Generator™</b> battery.
Equipment being operated draws too much power.	Reduce load to maximum 50 watts.
Inverter in thermal shutdown condition.	Allow inverter to cool down. Ensure that there is adequate ventilation around unit, and load is no more than 50 watts for continuous operation.
Main fuse failed (blown).	Replace <b>Pocket Generator™</b> fuse.

### Problem: Low Output Voltage

Using average reading voltmeter.	Use <b>true</b> RMS reading meter.
Inverter is overloaded.	Reduce load to 50 watts max. to maintain regulation.
Input voltage below 10.5 volts.	Keep input voltage above 10.5 volts to maintain regulation.

---

## SPECIFICATIONS: **Power Force 50™** Inverter

MAX. CONTINUOUS POWER . . . . .	50 WATTS	LOW VOLTAGE SHUTDOWN ACTIVATION . . . . .	10.0 VOLTS
PEAK SURGE CAPACITY . . . . .	80 WATTS	WAVE FORM . . . . .	MAX. SINE WAVE
MAX. EFFICIENCY . . . . .	±80%	# OF AC RECEPTACLES . . . . .	ONE
NO LOAD CURRENT DRAW . . . . .	<0.06A	FUSE . . . . .	10 AMP
INPUT VOLTAGE RANGE . . . . .	10 - 15 VDC		



### 3 YEAR EXTENDED WARRANTY REGISTRATION FORM

Certain Vector Manufacturing, Ltd. products are eligible to be covered to the original purchaser only, for three (3) years from the date of purchase, to be free of defects in materials or workmanship. Vector Manufacturing, Ltd. disclaims any liability for consequential damages. In no event will Vector Manufacturing, Ltd. be responsible for any amount of damages beyond the amount paid for the product at retail. In the event of a defective item, please ship the item to us, prepaid, with an explanation of the problem, your name, address and daytime telephone number. Vector Manufacturing, Ltd. will, at its option, replace or repair the defective part.

The following situations are not covered under this warranty:

- ✓ Cost of shipment to Vector Manufacturing, Ltd.
- ✓ Normal wear and tear, including chips, scratches, abrasions, discoloration or fading due to usage or exposure to sunlight.
- ✓ Damage caused by misuse, abuse, neglect, alterations, repairs by unauthorized persons, or failure to follow recommended care and use instructions.
- ✓ Bulbs, fuses and batteries.

Please activate my Extended Warranty for Model #VEC018-AC.

Name \_\_\_\_\_

Street Address \_\_\_\_\_ City \_\_\_\_\_

State \_\_\_\_\_ Zip Code \_\_\_\_\_

Phone \_\_\_\_\_ Fax \_\_\_\_\_ E-mail \_\_\_\_\_

Item Purchased \_\_\_\_\_

Date of Purchase \_\_\_\_\_

Store Where Purchased \_\_\_\_\_

UPC Number from package (12 digits) \_\_\_\_\_

Form of Payment (US\$20.00)    Check     Money Order

All Vector Manufacturing, Ltd. products must be registered within (10) days of purchase to activate this warranty. Mail the completed registration form, along with a copy of the original sales receipt, and a check or money order for US\$20.00 made payable to Vector Manufacturing, Ltd., to:

ATTN: CUSTOMER SERVICE  
VECTOR MANUFACTURING, LTD.  
3003 GREENE STREET  
HOLLYWOOD, FL 33020

WARRANTY MUST BE PURCHASED WITHIN 90 DAYS OF PRODUCT PURCHASE DATE.  
WARRANTY IS NON-TRANSFERABLE AND NON-REFUNDABLE.

Cut here



120 DAY LIMITED WARRANTY REGISTRATION FORM

All Vector Manufacturing, Ltd. products are warranted to the original purchaser only, for 120 days from the date of purchase, to be free of defects in materials and workmanship. In no event will Vector Manufacturing, Ltd. be responsible for any amount of damages beyond the retail purchase price of the product. All Vector Manufacturing, Ltd. products must be registered within (10) days of purchase. To activate this warranty, mail the completed registration form along with a copy of the original sales receipt to the address shown below.

TERMS OF REPAIR OR REPLACEMENT: In the event of a defective unit, return the unit to us within 30 days of the date of purchase, and we will replace it, free of charge. If returned after 30 days but within 120 days of the purchase date we will repair the unit or, at our option, replace it free of charge. If we repair the unit, we may use new or reconditioned replacement parts, at our option. If we elect to replace the unit, we may replace it with a new or reconditioned one of the same or comparable design. The repair or replacement unit will then be warranted under the terms of our standard 120 day warranty. The customer is responsible for shipping charges on all returned items. During the warranty period, Vector Manufacturing, Ltd. will be responsible for the repair or replacement cost plus the return shipping charges.

LIMITATIONS: Implied warranties, including those of fitness for a particular purpose and merchantability (an unwritten warranty that the product is fit for ordinary use), are limited to 120 days from the purchase date. Vector Manufacturing, Ltd. will not reimburse for loss of time, inconvenience, loss of use of a product, or property damage caused by a product or its failure to work, or any other incidental or inconsequential damages, including personal injury.

EXCLUSIONS: This warranty does not cover bulbs, fuses and batteries, defects resulting from normal wear and tear (including chips, scratches, abrasions, discoloration or fading due to usage or exposure to sunlight), accidents, damage during shipping to our service facility, alterations, unauthorized use or repair, neglect, misuse, abuse, failure to follow instructions for care and maintenance, fire, flood, and Acts of God. If your problem is not covered by this warranty, call our customer service facility at (954) 923-1155 for general repair information and charges. This limited warranty is the only one that applies to this product, and sets forth all the responsibilities of Vector Manufacturing, Ltd. regarding this product. There are no warranties which extend beyond those described herein.

STATE LAW RIGHTS: Some states do not allow limitations on how long an implied warranty lasts or the exclusion or limitation of incidental or consequential damages, so the exclusions or limitations stated herein may not apply. This warranty gives the purchaser specific legal rights; other rights, varying from state to state, may apply.

TO REQUEST WARRANTY SERVICE FOR THIS PRODUCT: Within 30 days of the purchase date, return the unit, along with the dated sales receipt, to the place of purchase for immediate replacement. After 30 days, but within the 120 day warranty period, you may return the product to the address shown below. We suggest that you retain the original packaging in case you need to ship the unit. When returning a product, include your name, address, phone number, dated sales receipt, and a description of the reason for return. After repairing or replacing the unit, we will return it to you within four weeks.

VECTOR MANUFACTURING, Ltd.
3003 Greene Street
Hollywood, FL 33020

[ ] Please activate my Limited Warranty for Model #VEC018-AC.
I have enclosed a copy of the original sales receipt.

Name \_\_\_\_\_ Street Address \_\_\_\_\_
City \_\_\_\_\_ State \_\_\_\_\_ Zip Code \_\_\_\_\_
Phone \_\_\_\_\_ Fax \_\_\_\_\_ E-mail \_\_\_\_\_

Item Purchased \_\_\_\_\_
Date of Purchase \_\_\_\_\_
Store Where Purchased \_\_\_\_\_
UPC Number from package (12 digits) \_\_\_\_\_

All Vector Manufacturing, Ltd. products must be registered within (10) days of purchase to activate this warranty. Mail the completed registration form, along with a copy of the original sales receipt, to:

ATTN: CUSTOMER SERVICE
VECTOR MANUFACTURING, LTD.
3003 GREENE STREET
HOLLYWOOD, FL 33020

Cut here